



Abbildungen/Daten/Diagramme unverbindlich
Illustrations/Dates/Graphs without engagement

Drehschieberpumpe für nicht

- giftige
- brennbare
- explosive Gase

Rotary vane pump for non

- toxic
- flammable
- explosive gases

Spannung/voltage 24V

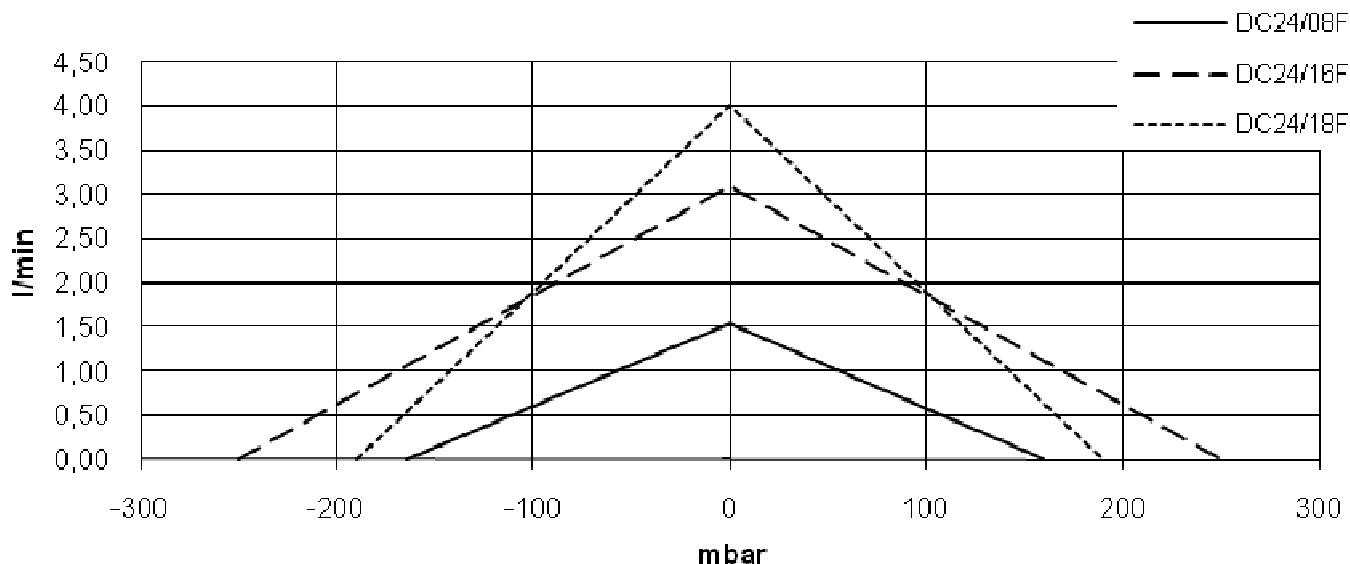

Typ/Model	Gewicht weight g	Nennstrom Nominate current mA	Spannung voltage V	Volumenstrom flow l/(min)	Vakuum vacuum				Druck pressure			
					Strom current		[-] mbar	Lautstärke noise level dB(A)	Strom current		[+] mbar	Lautstärke noise level dB(A)
					min. mA	max. mA			min. mA	max. mA		
DC24/08F Art.-Nr.: 16513	98	210	24,0	1,5	55	90	165	66	55	90	160	62
			18,0	1,2	40	60	110	57	40	65	110	57
			12,0	0,8	25	40	50	51	25	40	50	50
DC24/16F Art.-Nr.: 16713			24,0	3,1	70	145	250	68	80	160	250	66
			18,0	2,4	50	100	140	63	50	105	140	62
			12,0	1,7	35	60	75	57	35	50	75	54
DC24/18F Art.-Nr.: 16813			24,0	4,0	85	145	190	72	95	150	190	72
			18,0	3,1	65	100	125	67	65	100	125	65
			12,0	2,0	40	60	60	60	40	60	65	56

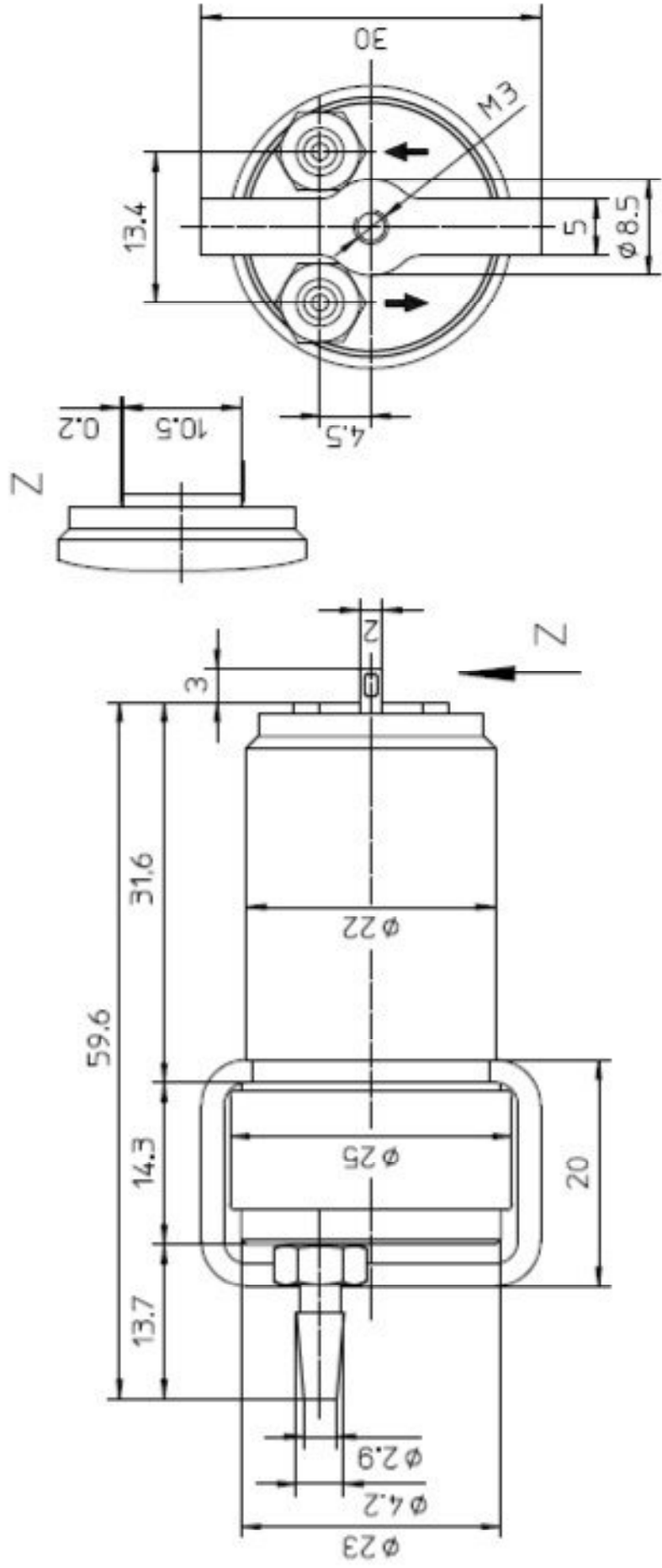

Fürgut GmbH Lärchenweg 12 D-88459 Tammheim Tel. 08395 936633 Fax. 08395 936634	Untertiererte Maße ISO 2768-m		2:1 Maßstab		Benennung Vakuumpumpe Vacuum pump
		Datum	Notiz		
	Erstellt	12.08.2010	Dr. Giacomini		DC 06 / 08 F
	Geprüft				DC 06 / 16 F
					DC 06 / 18 F
					DC 12 / 08 FK
					DC 12 / 16 FK
					DC 12 / 18 FK
© 2010 Fürgut GmbH, alle Rechte vorbehalten Fürgut GmbH, Tammheim, Germany	Datum	25.08.10	Dr.C.		DC 24 / 08 F
Info:	Änderung				DC 24 / 16 F
					DC 24 / 18 F
					K = Kugellager K = ball bearing

Type/Model: DC24/08F

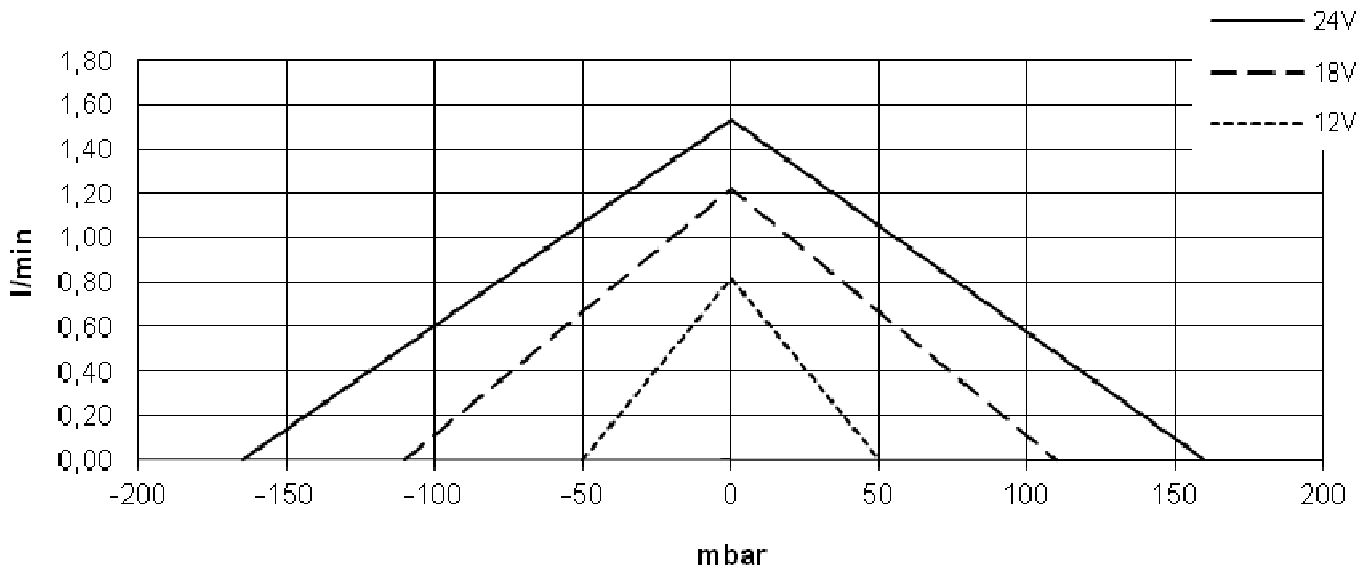

Type/Model: DC24/16F

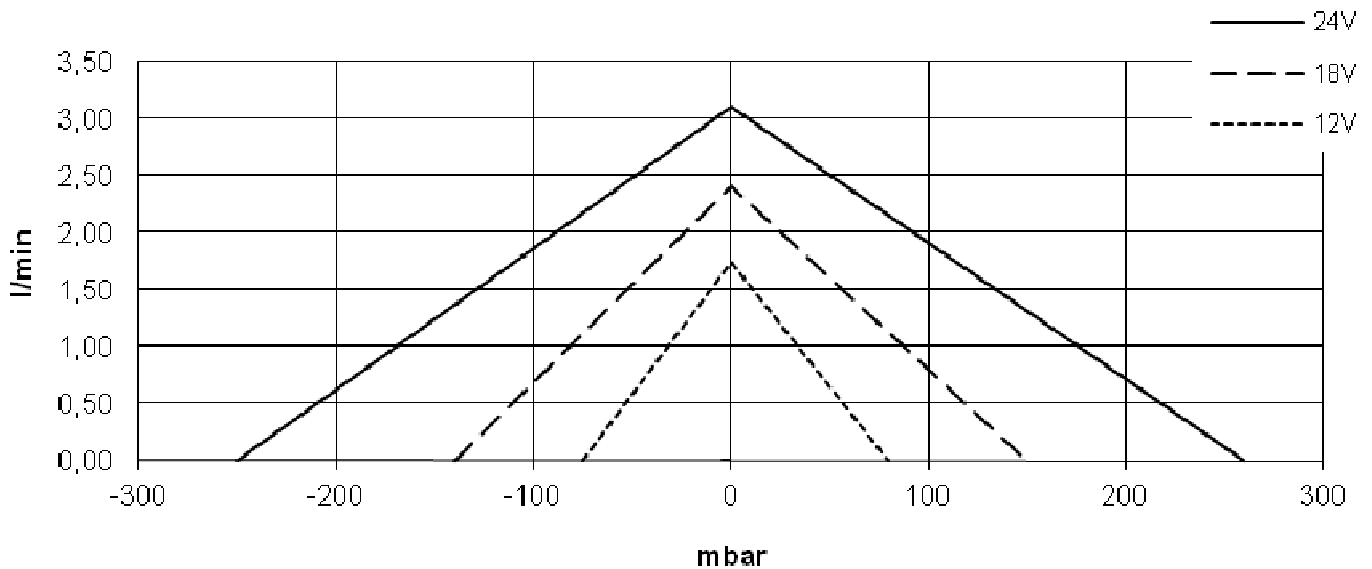

Type/Model: DC24/18F

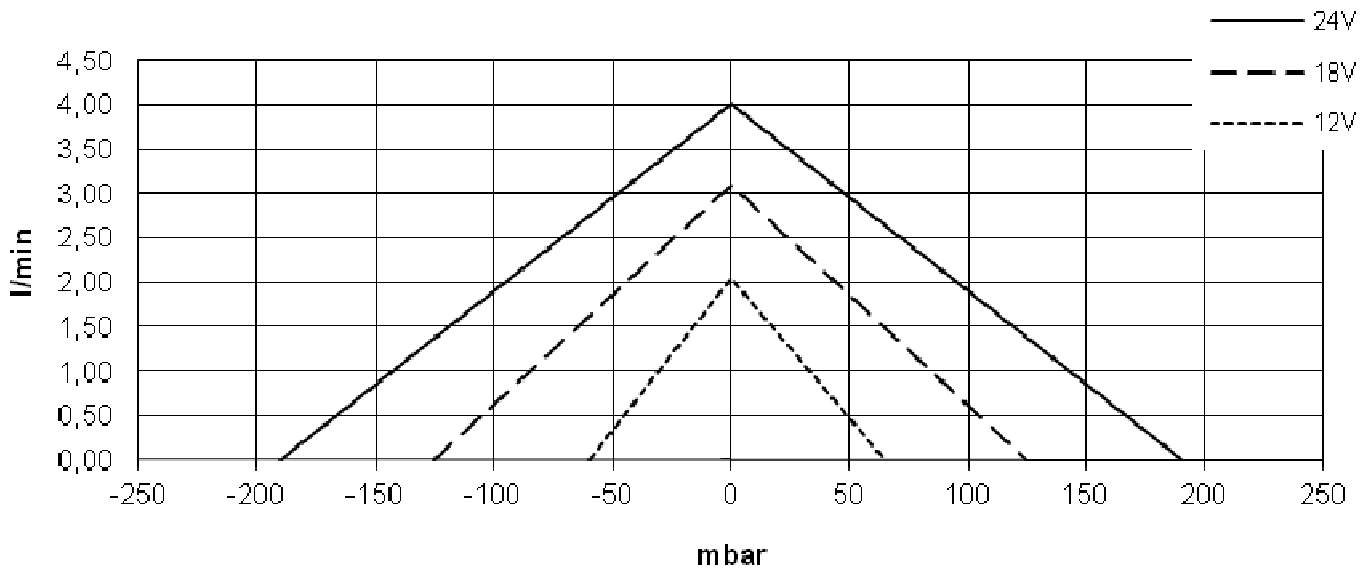

Verwendung / Usage

<p>Vor der Benutzung muss die Fürgut GmbH über die Applikation unterrichtet werden!!! Before use, the Fürgut GmbH will be notified of the application!!!</p>					

Montage und Demontage (elektrisch) / Installation and deinstallation (electric)

				<p>Spannung wie vereinbart! Jedoch max. Nennspannung!!! Polung (+/-) beachten!</p> <p>Voltage as agreed! But only max. nominal voltage!!! Pay attention on polarity (+/-)!</p>
<p>Wichtig! / Important!!!</p> <p><u>DC</u>.. / 08;16;18F (Nennspannung beträgt .. Volt DC/ Nominal voltage is .. Volt DC)</p>				

Montage und Demontage (mechanisch) / Installation and deinstallation (mechanic)

			<p>Keine Kraft- oder Momenteinwirkung (in jeder Richtung) auf den Pumpenkopf!!!</p> <p>No force or torque (in any direction) at the pump head!!!</p>

Transport und Lagerung / Transport and storage

		<p>Transport und Lagerung nur in der Originalverpackung!!!</p> <p>Transport and storage only in the original box!!!</p>