



Abbildungen/Daten/Diagramme unverbindlich
Illustrations/Dates/Graphs without engagement

Drehschieberpumpe für nicht

- giftige
- brennbare
- explosive Gase

Rotary vane pump for non

- toxic
- flammable
- explosive gases

max. Spannung/max. voltage

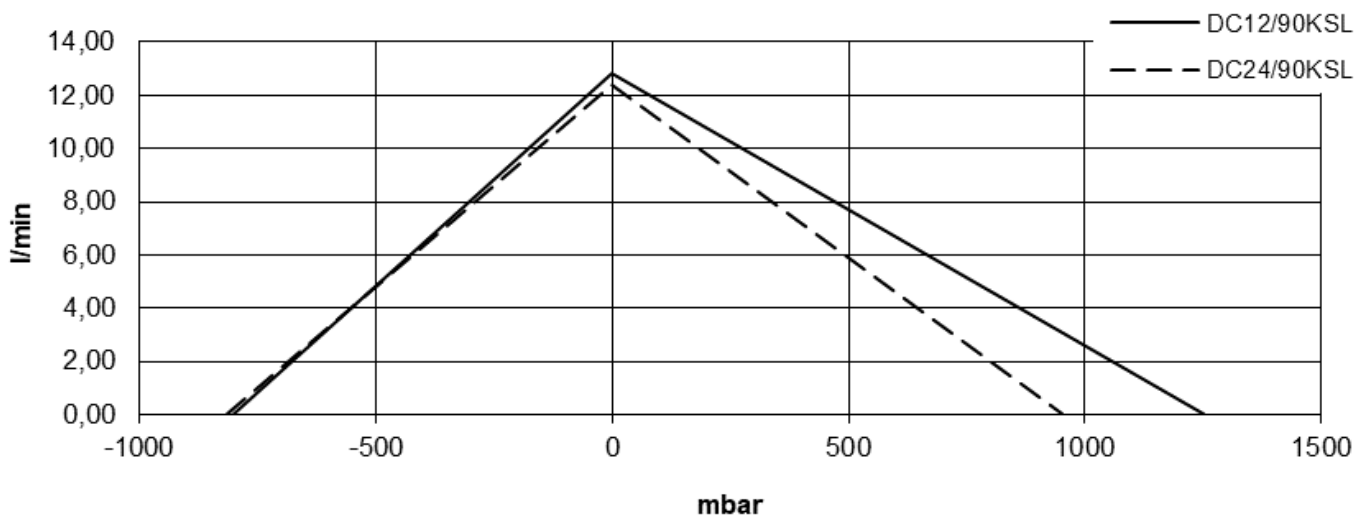

| Typ/Model | Gewicht weight kg | Nennstrom Nominate current A | Spannung voltage V | Volumenstrom flow l/(min) | Vakuum vacuum | | | | Druck pressure | | | |
|-------------------------------|-------------------------|---------------------------------------|--------------------------|---------------------------------|------------------|-----------|-------------|---------------------------------------|-------------------|-----------|-------------|---------------------------------------|
| | | | | | Strom current | | [-] mbar | Lautstärke noise level dB(A) | Strom current | | [+] mbar | Lautstärke noise level dB(A) |
| | | | | | min. A | max. A | | | min. A | max. A | | |
| DC12/90KSL Art.-Nr.: 16004 | 0,79 | 2,81 | 12,0 | 12,8 | 1,8 | 3,2 | 800 | 75 | 1,8 | 6,8 | 1250 | 71 |
| | | | 9,0 | 9,3 | 1,3 | 3,1 | 750 | 74 | 1,4 | 5,1 | 1100 | 68 |
| | | | 6,0 | 5,6 | 1,0 | 2,8 | 540 | 65 | 1,0 | 3,2 | 580 | 62 |
| DC24/90KSL Art.-Nr.: 16104 | | 1,22 | 24,0 | 12,3 | 0,8 | 1,4 | 815 | 82 | 1,0 | 2,8 | 950 | 71 |
| | | | 18,0 | 8,7 | 0,7 | 1,3 | 725 | 79 | 0,7 | 2,2 | 1000 | 65 |
| | | | 12,0 | 5,4 | 0,5 | 1,1 | 550 | 73 | 0,5 | 1,5 | 620 | 59 |
| | | | | | | | | | | | | |
| | | | | | | | | | | | | |

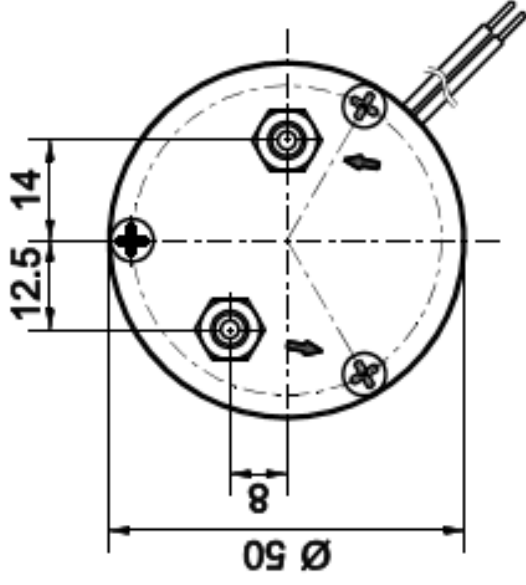
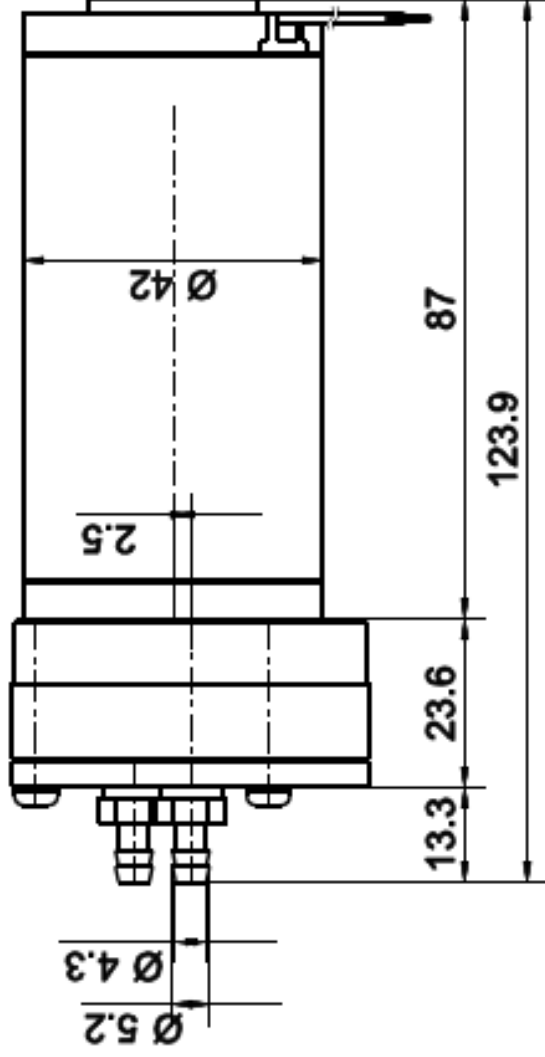

Litzen
 AWG 18 UL - Style 1569
 schwarz / rot
 L=300 +/-30 ab Flansch
 Litzenenden 7 +/-1mm
 abisoliert und verzinkt

| | | | | | |
|---|----------|------------------------------------|-----------|---------------|--|
| Fürgut GmbH Lärchweg 12 D-84459 Teisbach Tel. 08395 93633 Fax. 08395 93634 | | Unterlieferante Info ISO 2768-m | | Material: | |
| | | Debitum | Name | Benennung: | |
| | | Erstellter | R. Fürgut | Vakuumpumpe | |
| | | Gegrüßt | X | Vacuum pump | |
| | | | | DC 12 / 90KSL | |
| | | | | Zeichnung: | |
| | | | | 1:1 | |
| Index | Änderung | Debitum | Name | Maßstab | |

Type/Model: DC12/90KSL

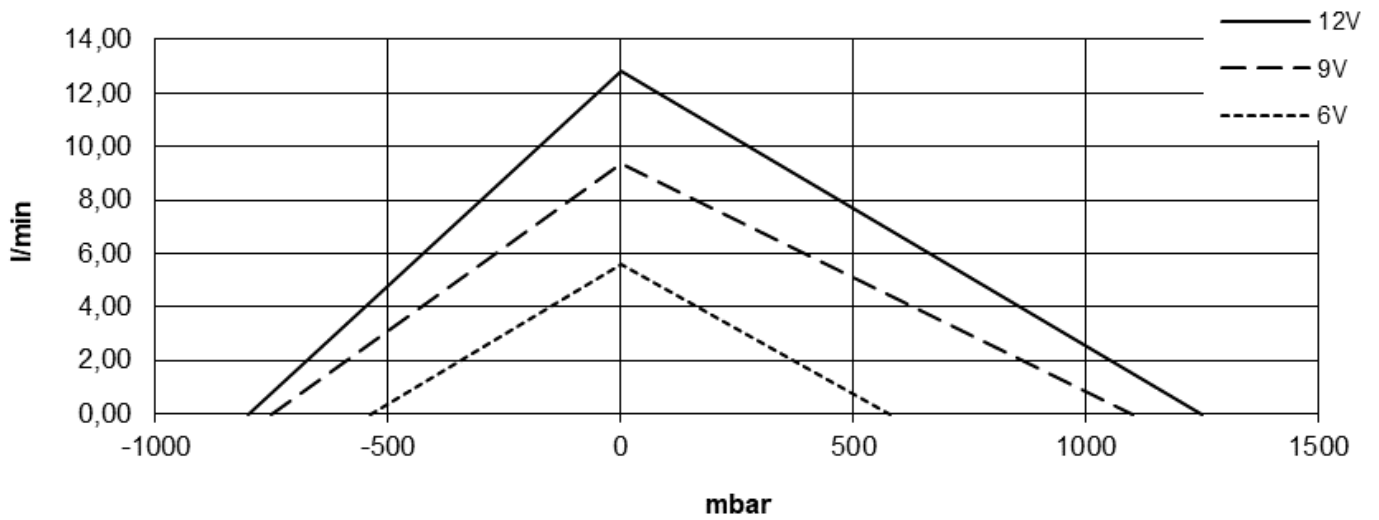

Type/Model: DC24/90KSL

