



Abbildung unverbindlich
Illustration without engagement

Drehschieberpumpe für nicht

- giftige
- brennbare
- explosive Gase

Rotary vane pump for non

- toxic
- flammable
- explosive gases

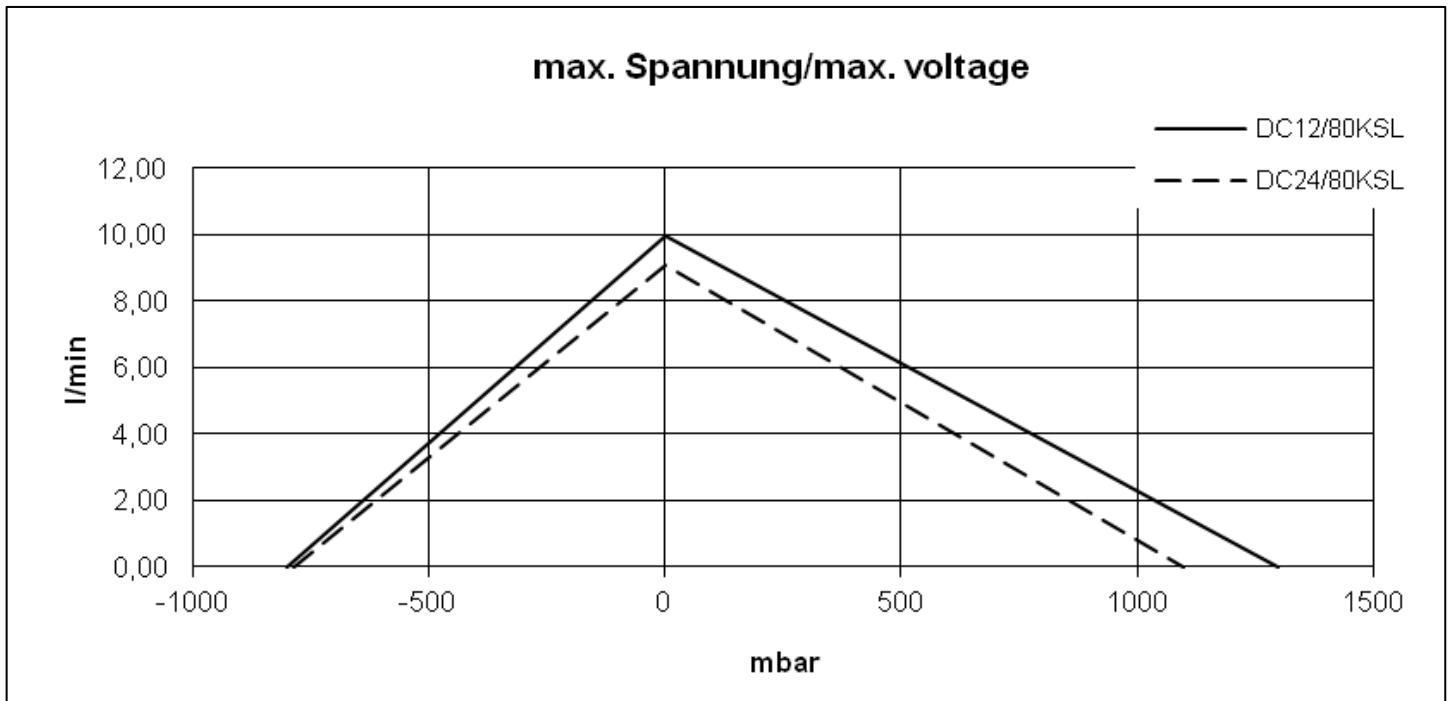

Typ/Model	Gewicht weight kg	Nennstrom Nominate current A	Spannung voltage V	Volumenstrom flow l/(min)	Vakuum vacuum				Druck pressure			
					Strom current		[-] mbar	Lautstärke noise level dB(A)	Strom current		[+] mbar	Lautstärke noise level dB(A)
					min. A	max. A			min. A	max. A		
DC12/80KSL Art.-Nr.: 16003	0,79	2,81	12,0	9,9	1,5	2,5	800	83	1,6	5,4	1300	72
			9,0	7,5	1,3	2,4	760	80	1,3	4,4	930	67
			6,0	4,7	1,0	2,1	640	72	1,0	3,0	730	59
DC24/80KSL Art.-Nr.: 16103		1,22	24,0	9,0	0,7	1,2	785	84	0,8	1,9	1100	74
			18,0	6,6	0,6	1,0	740	79	0,7	1,9	1200	68
			12,0	4,3	0,5	1,0	630	74	0,5	1,4	750	62
Art.-Nr.:												
Art.-Nr.:												

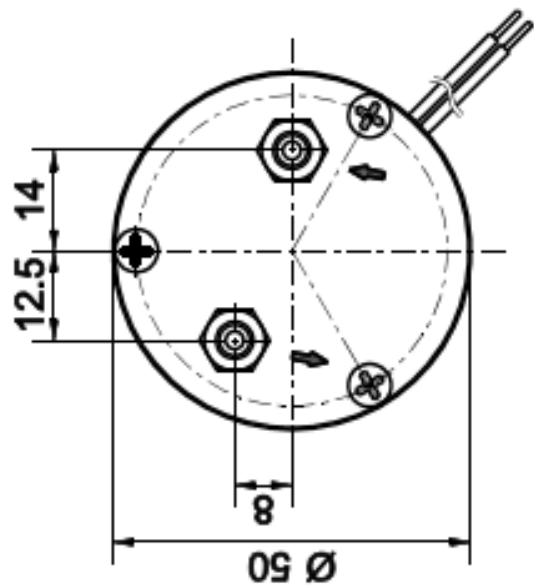
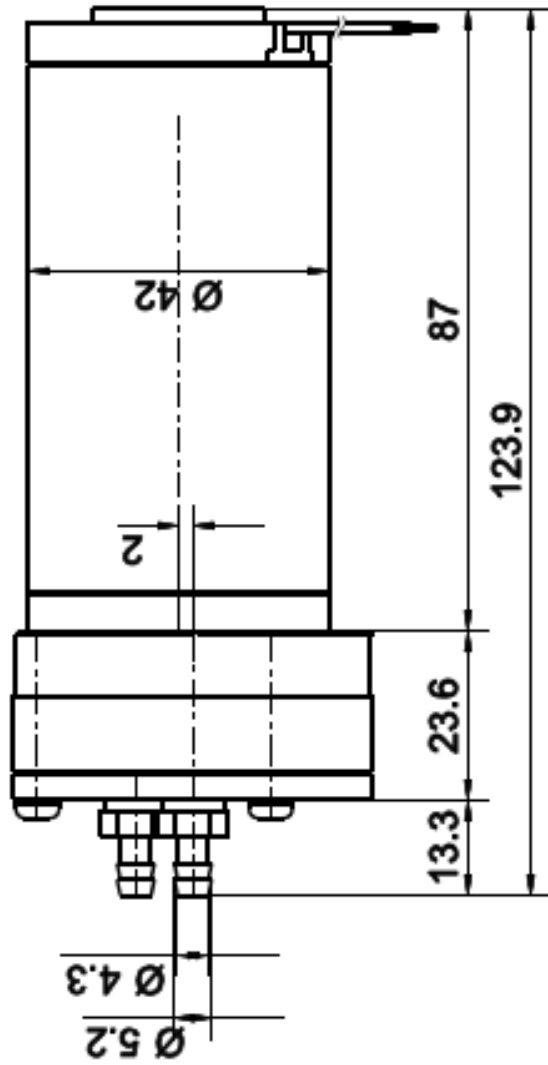

Litzen
 AWG 18 UL - Style 1569
 schwarz / rot
 L=300 +/-30 ab Flansch
 Litzenenden 7 +/-1mm
 abisoliert und verzinkt

Förgut GmbH Lärchenweg 12 D-88459 Teisheile Tel. 08395 996833 Fax 08395 996834		Unterbierle Mabo ISO 2708-m		Material:	
		Datum	Name	Bestimmung:	
		Erstellt	R. Förgut	Vakuumpumpe	
		Geprüft	X	Vacuum pump	
				DC 12 / 80KSL	
				Zeichnung:	
				1:1	
Index	Änderung	Datum	Name	Maßstab	

Type/Model: DC12/80KSL

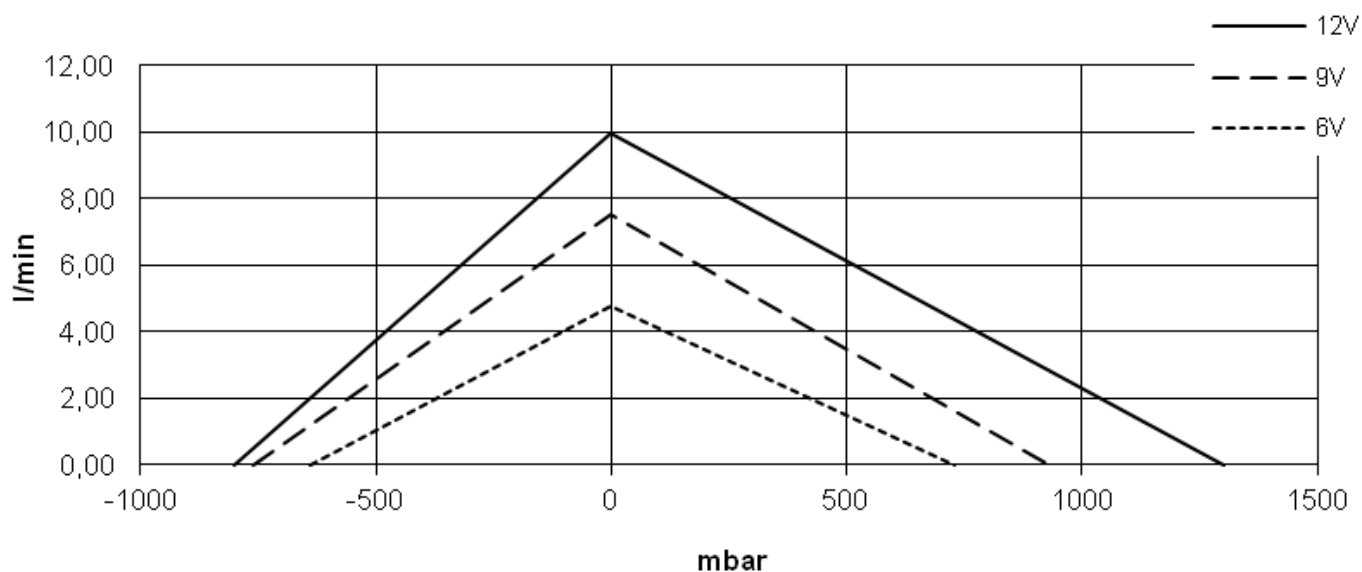

Type/Model: DC24/80KSL

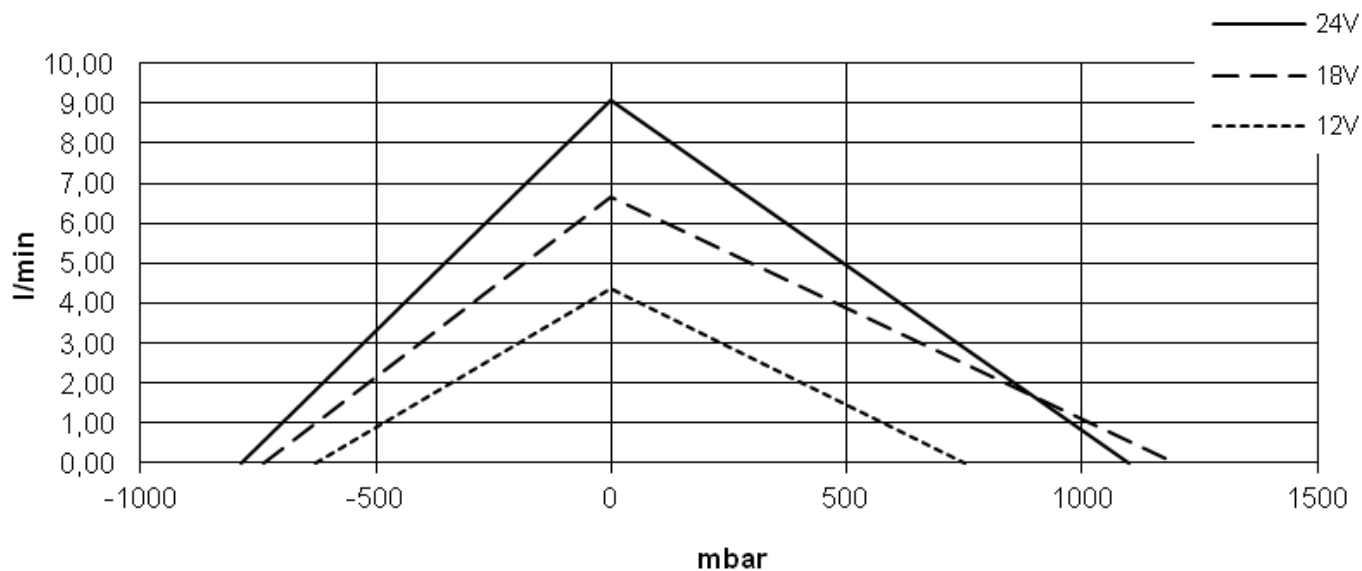

Verwendung / Usage

<p>Vor der Benutzung muss die Fürgut GmbH über die Applikation unterrichtet werden!!! Before use, the Fürgut GmbH will be notified of the application!!!</p>					

Montage und Demontage (elektrisch) / Installation and deinstallation (electric)

				<p>Spannung wie vereinbart! Jedoch max. Nennspannung!!! Polung (+/-) beachten!</p> <p>Voltage as agreed! But only max. nominal voltage!!! Pay attention on polarity (+/-)!</p>
<p>Wichtig! / Important!!!</p> <p><u>DC../80SL;90SL</u> (Nennspannung beträgt .. Volt DC/ Nominal voltage is .. Volt DC)</p>				

Montage und Demontage (mechanisch) / Installation and deinstallation (mechanic)

			<p>Keine Kraft- oder Momenteinwirkung (in jeder Richtung) auf den Pumpenkopf!!!</p> <p>No force or torque (in any direction) at the pump head!!!</p>

Transport und Lagerung / Transport and storage

		<p>Transport und Lagerung nur in der Originalverpackung!!!</p> <p>Transport and storage only in the original box!!!</p>